

**Exhibit 10**



# HIGH SCHOOL AT WILDCREEK PEDESTRIAN IMPROVEMENTS

# Exhibit 11a



New Sidewalk  
by WCSD north  
side of  
El Rancho Dr.

El Rancho Dr

15 mph School  
Zone Flasher  
(Between  
Roundabouts)

Sullivan Ln

Potential Transit  
Stop Location  
(TBD with RTC)

15 mph School  
Zone Flasher  
(South of  
Roundabouts)

New Sidewalk  
by WCSD  
north side of  
McCarran Blvd

New Sidewalk  
by WCSD  
east side of  
Sullivan Ln.

N. McCarran Blvd

## Legend

 New Sidewalk Facilities

# HIGH SCHOOL AT WILDCREEK BICYCLE IMPROVEMENTS

Exhibit 11b

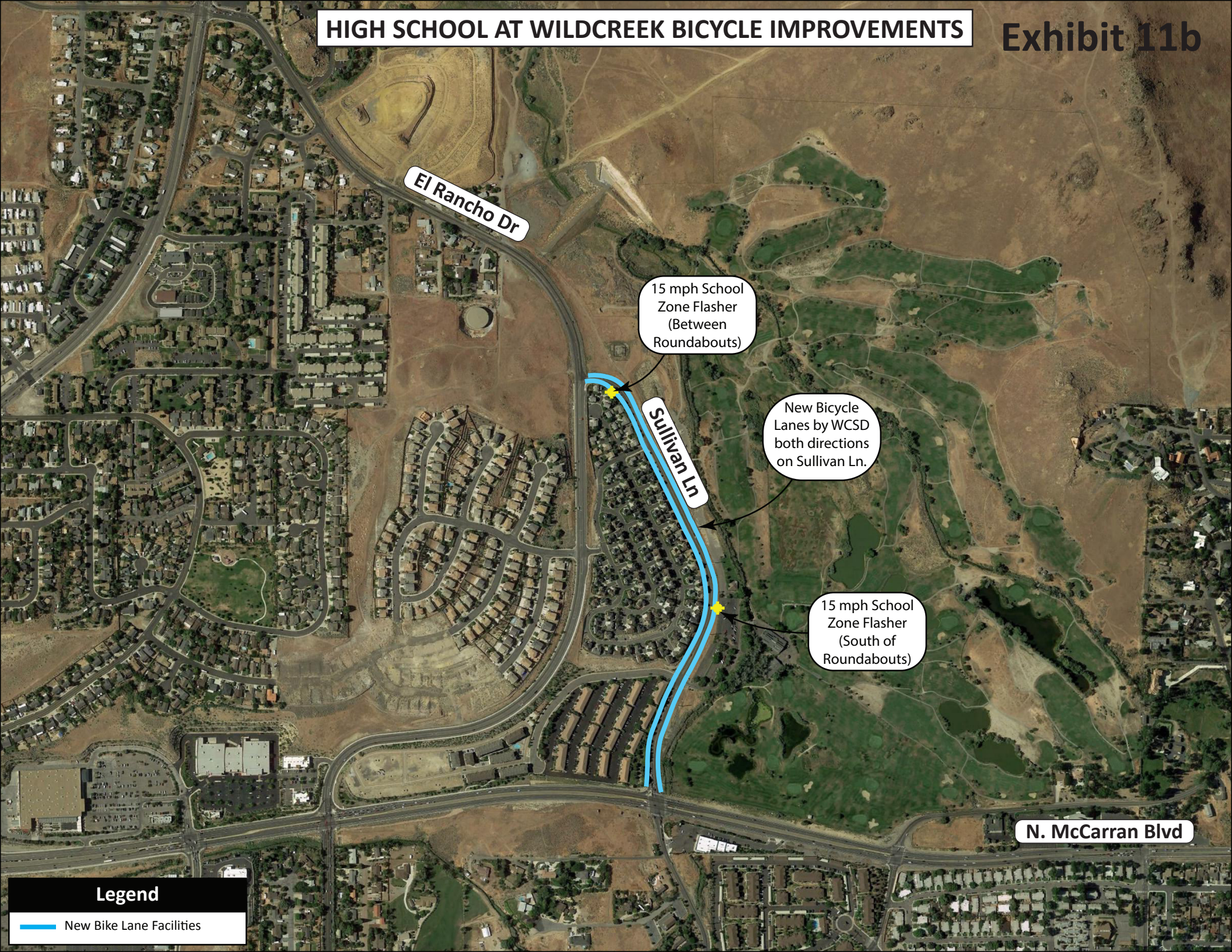

El Rancho Dr

15 mph School Zone Flasher (Between Roundabouts)

Sullivan Ln

New Bicycle Lanes by WCSD both directions on Sullivan Ln.

15 mph School Zone Flasher (South of Roundabouts)

N. McCarran Blvd

## Legend

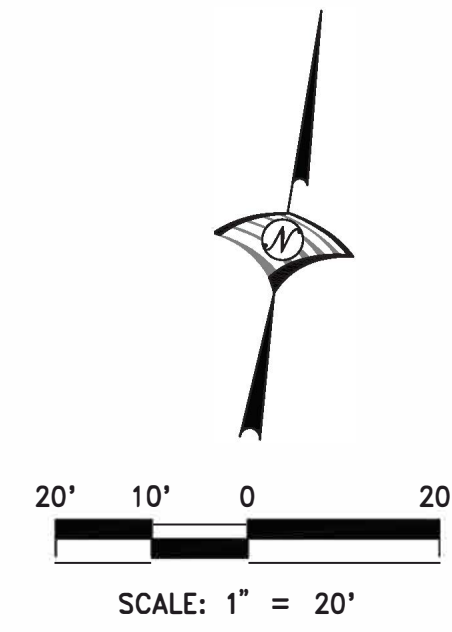

 New Bike Lane Facilities



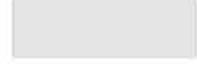
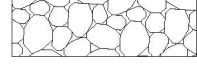

**CONSTRUCTION NOTES:**

1. ALL SEWER AND STORM DRAIN IMPROVEMENTS ARE PUBLIC UNLESS NOTED OTHERWISE.
2. EXISTING UTILITY TIE-IN INFORMATION HAS BEEN OBTAINED FROM BOTH RECORD DRAWINGS AND FIELD SURVEY WHERE EXISTING IMPROVEMENTS COULD BE LOCATED. CONTRACTOR TO VERIFY ACCURACY OF INFORMATION PRIOR TO CONSTRUCTION AND TO NOTIFY ENGINEER OF ANY DISCREPANCIES FOUND BEFORE COMMENCING WORK.
3. REFER TO HORIZONTAL CONTROL PLAN FOR CENTERLINE INFORMATION (HC-01).
4. THERE SHALL BE 24" MINIMUM COVER OVER THE INVERTED SIPHON SD LINE.
5. REFERENCE DM SHEETS FOR GENERAL PROTECT IN PLACE NOTES.
6. ALL DIMENSIONS AND DISTANCES ARE TO BACK OF CURB, CURB RETURN, FACE OF WALL, FLOW LINE, PROPERTY LINE, CENTER OF STRIPING, CENTER LINE OF PIPE, OR END OF IMPROVEMENTS.
7. ALL SLOPES ARE 3:1 OR LESS UNLESS NOTED OTHERWISE.
8. ADD 4400 FEET TO ALL ELEVATIONS.

**LEGEND:**

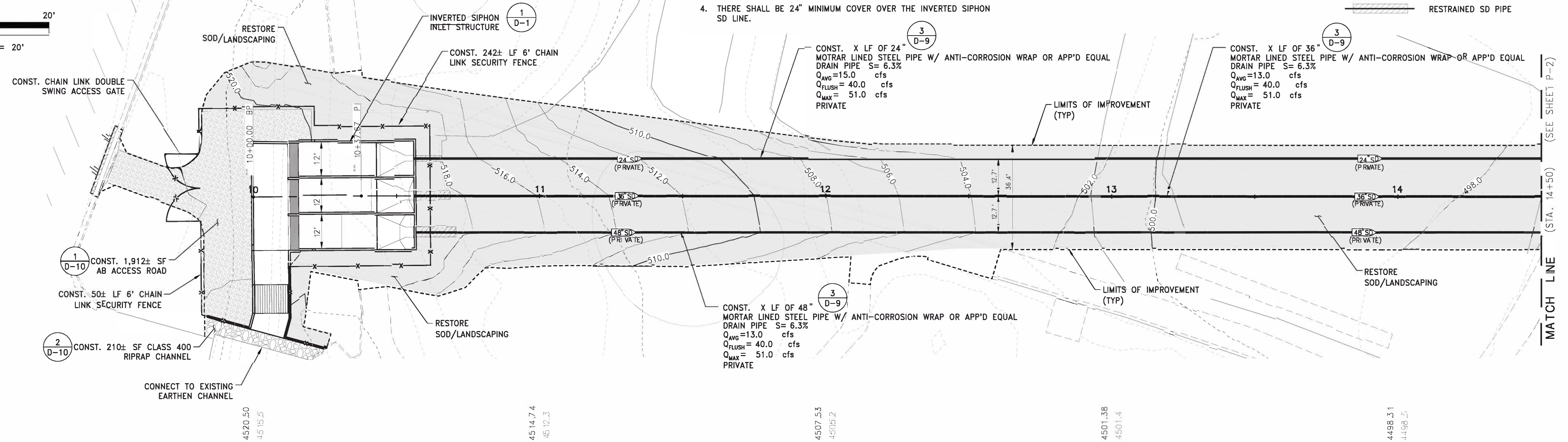
-  PROPOSED ASPHALT CART PATH
-  RESTORE SOD/LANDSCAPING
-  PROPOSED RIPRAP
-  PROPOSED AGGREGATE BASE ROAD
-  RESTRAINED SD PIPE



EXISTING GROUND @   
 PROP. Q GRADES 

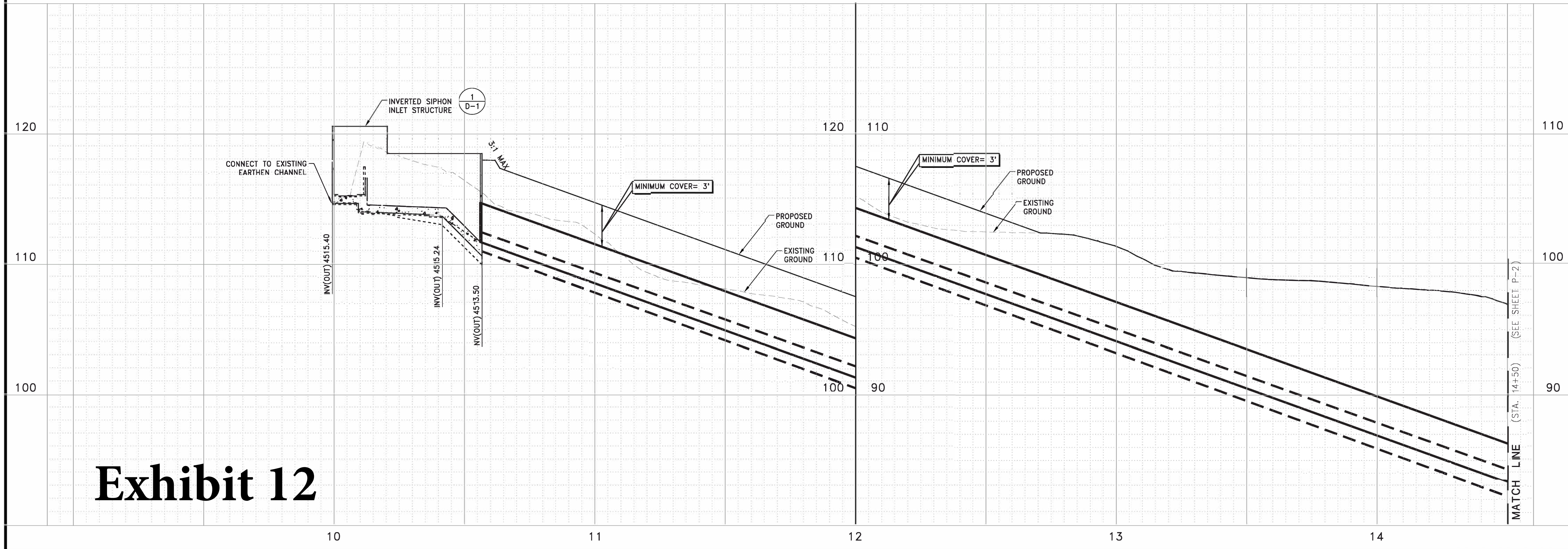

**Exhibit 12**

**PRELIMINARY - DEVELOPMENT AGREEMENT SUBMITTAL**

DATE: APRIL 2019  
 SCALE: H:1"=20' V:1"=5'  
 DRAWN BY: DAD  
 DESIGNED BY: DAD  
 CHECKED BY: MAC

**WOOD ROGERS**  
 BUILDING RELATIONS  
 1981 Corporate Blvd  
 Reno, NV 89502  
 Tel: 775.823.4068  
 Fax: 775.823.4066

**Washoe County School District**  
 Every Child, by Name And Free To Graduation  
 1800 S. Virginia Street, Reno, NV 89502  
 Phone: 775.784.1234  
 Fax: 775.784.1234

**IMPROVEMENT PLANS FOR ORR DITCH REALIGNMENT INVERTED SIPHON PLAN AND PROFILE**

PROJECT NO. 8052.001  
 DRAWING P-1



20' 10' 0 20'  
SCALE: 1" = 20'

**CONSTRUCTION NOTES:**

1. ALL SEWER AND STORM DRAIN IMPROVEMENTS ARE PUBLIC UNLESS NOTED OTHERWISE.
2. EXISTING UTILITY TIE-IN INFORMATION HAS BEEN OBTAINED FROM BOTH RECORD DRAWINGS AND FIELD SURVEY WHERE EXISTING IMPROVEMENTS COULD BE LOCATED. CONTRACTOR TO VERIFY ACCURACY OF INFORMATION PRIOR TO CONSTRUCTION AND TO NOTIFY ENGINEER OF ANY DISCREPANCIES FOUND BEFORE COMMENCING WORK.
3. REFER TO HORIZONTAL CONTROL PLAN FOR CENTERLINE INFORMATION (HC-01).
4. THERE SHALL BE 24" MINIMUM COVER OVER THE INVERTED SIPHON SD LINE.
5. REFERENCE DM SHEETS FOR GENERAL PROTECT IN PLACE NOTES.
6. ALL DIMENSIONS AND DISTANCES ARE TO BACK OF CURB, CURB RETURN, FACE OF WALL, FLOW LINE, PROPERTY LINE, CENTER OF STRIPING, CENTER LINE OF PIPE, OR END OF IMPROVEMENTS.
7. ALL SLOPES ARE 3:1 OR LESS UNLESS NOTED OTHERWISE.
8. ADD 4400 FEET TO ALL ELEVATIONS.

**LEGEND:**

- PROPOSED ASPHALT CART PATH
- RESTORE SOD/LANDSCAPING
- PROPOSED RIPRAP
- PROPOSED GABIAN STRUCTURE

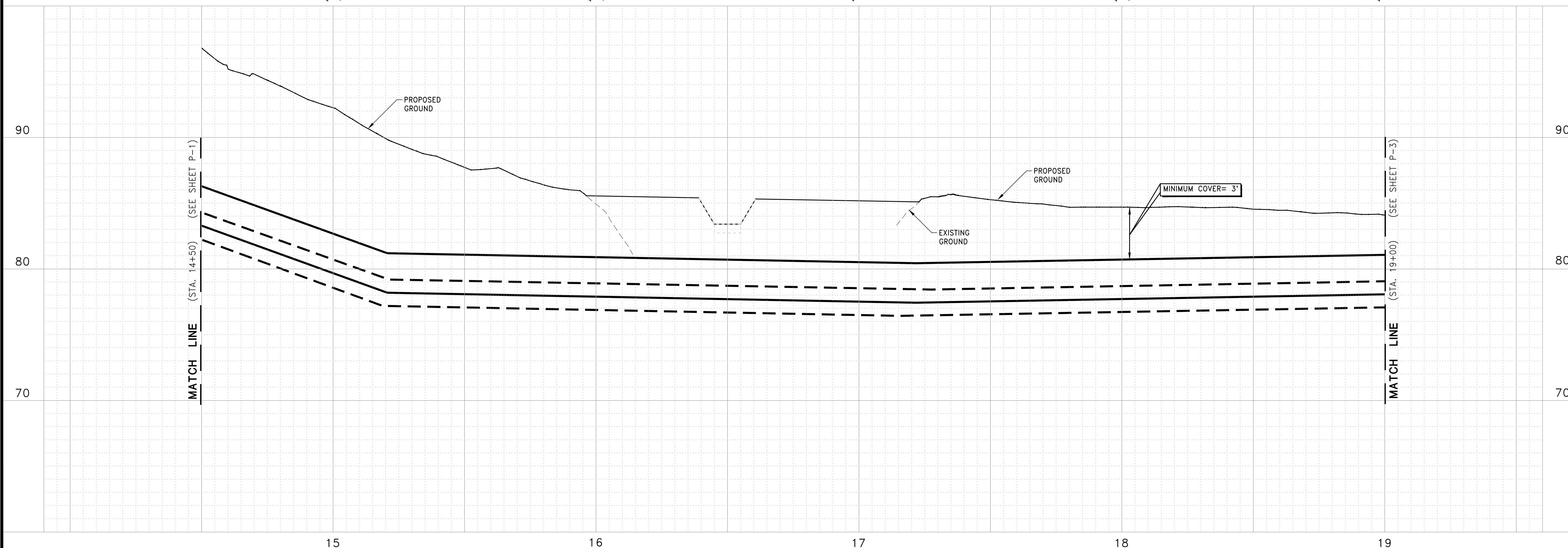
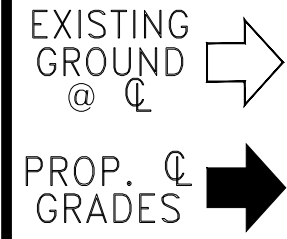
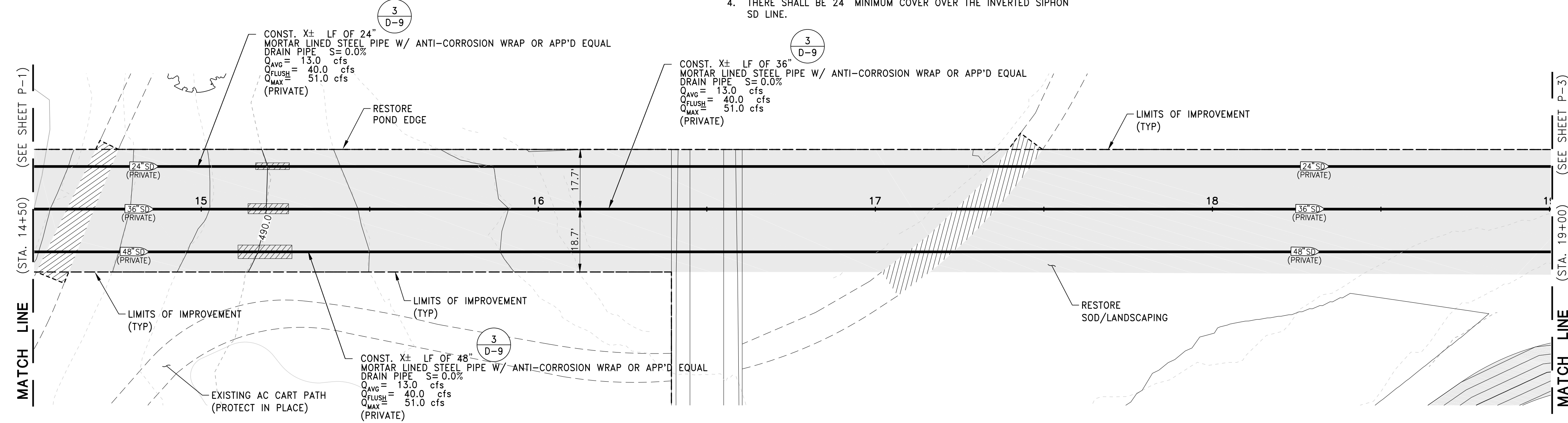

**PRELIMINARY - DEVELOPMENT AGREEMENT SUBMITTAL**

DATE: APRIL 2019  
SCALE: H: 1" = 10' V: 1" = 5'  
DRAWN BY: DAD  
DESIGNED BY: DAD  
CHECKED BY: MAC

**WOOD ROGERS**  
BUILDING RELATIONSHIPS ONE PROJECT AT A TIME  
1981 Corporate Blvd  
Reno, NV 89502  
Tel: 775.823.4068  
Fax: 775.823.4068

**Washoe County School District**  
Every Child, By Name And Face, To Graduation™

**IMPROVEMENT PLANS FOR ORR DITCH REALIGNMENT INVERTED SIPHON PLAN AND PROFILE**

PROJECT NO. 8052.001  
DRAWING P-2

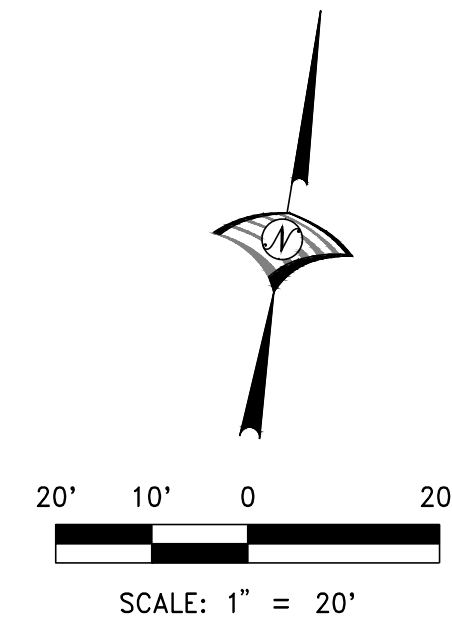

J:\Users\8052\_Washoe County School District\Washoe High School\ - Withdraw HS Orr Ditch Realignm\Civil\Draw\009\_PP02\_MCHS\_BPH.dwg 3/27/2019 5:37 PM Doug Dai Part 0





**CONSTRUCTION NOTES:**

1. ALL SEWER AND STORM DRAIN IMPROVEMENTS ARE PUBLIC UNLESS NOTED OTHERWISE.
2. EXISTING UTILITY TIE-IN INFORMATION HAS BEEN OBTAINED FROM BOTH RECORD DRAWINGS AND FIELD SURVEY WHERE EXISTING IMPROVEMENTS COULD BE LOCATED. CONTRACTOR TO VERIFY ACCURACY OF INFORMATION PRIOR TO CONSTRUCTION AND TO NOTIFY ENGINEER OF ANY DISCREPANCIES FOUND BEFORE COMMENCING WORK.
3. REFER TO HORIZONTAL CONTROL PLAN FOR CENTERLINE INFORMATION (HC-01).
4. THERE SHALL BE 24" MINIMUM COVER OVER THE INVERTED SIPHON SD LINE.
5. REFERENCE DM SHEETS FOR GENERAL PROTECT IN PLACE NOTES.
6. ALL DIMENSIONS AND DISTANCES ARE TO BACK OF CURB, CURB RETURN, FACE OF WALL, FLOW LINE, PROPERTY LINE, CENTER OF STRIPING, CENTER LINE OF PIPE, OR END OF IMPROVEMENTS.
7. ALL SLOPES ARE 3:1 OR LESS UNLESS NOTED OTHERWISE.
8. ADD 4400 FEET TO ALL ELEVATIONS.

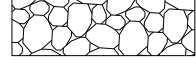
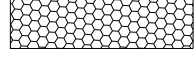
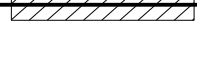
**LEGEND:**

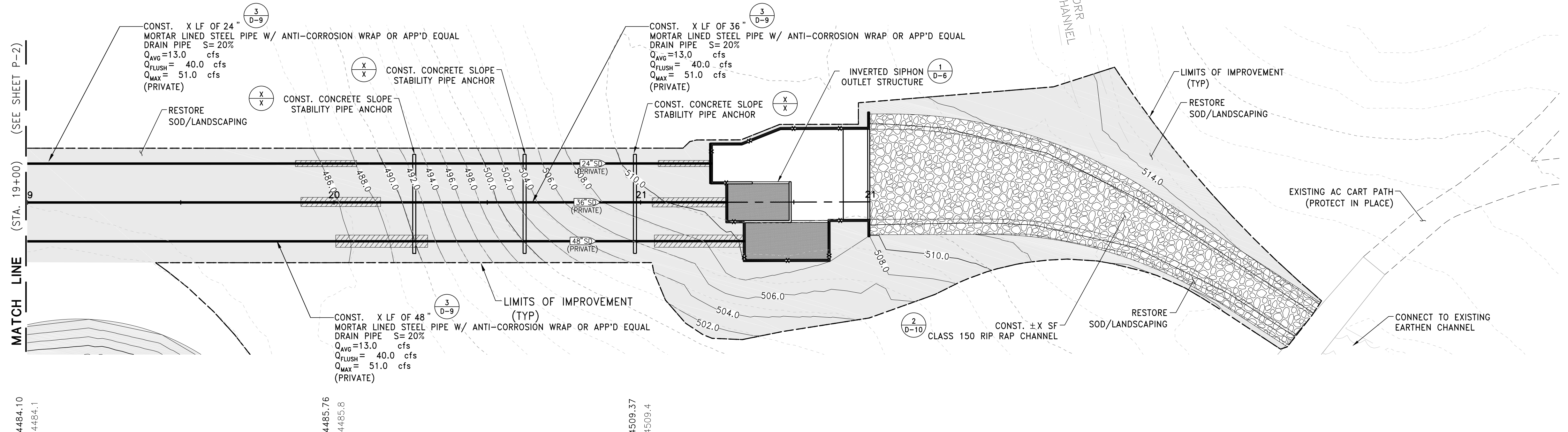
-  PROPOSED ASPHALT CART PATH
-  RESTORE SOD/LANDSCAPING
-  PROPOSED RIPRAP
-  PROPOSED GABIAN STRUCTURE
-  RESTRAINED SD PIPE

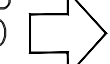

EXISTING GROUND @   
 PROP. GRADES @ 

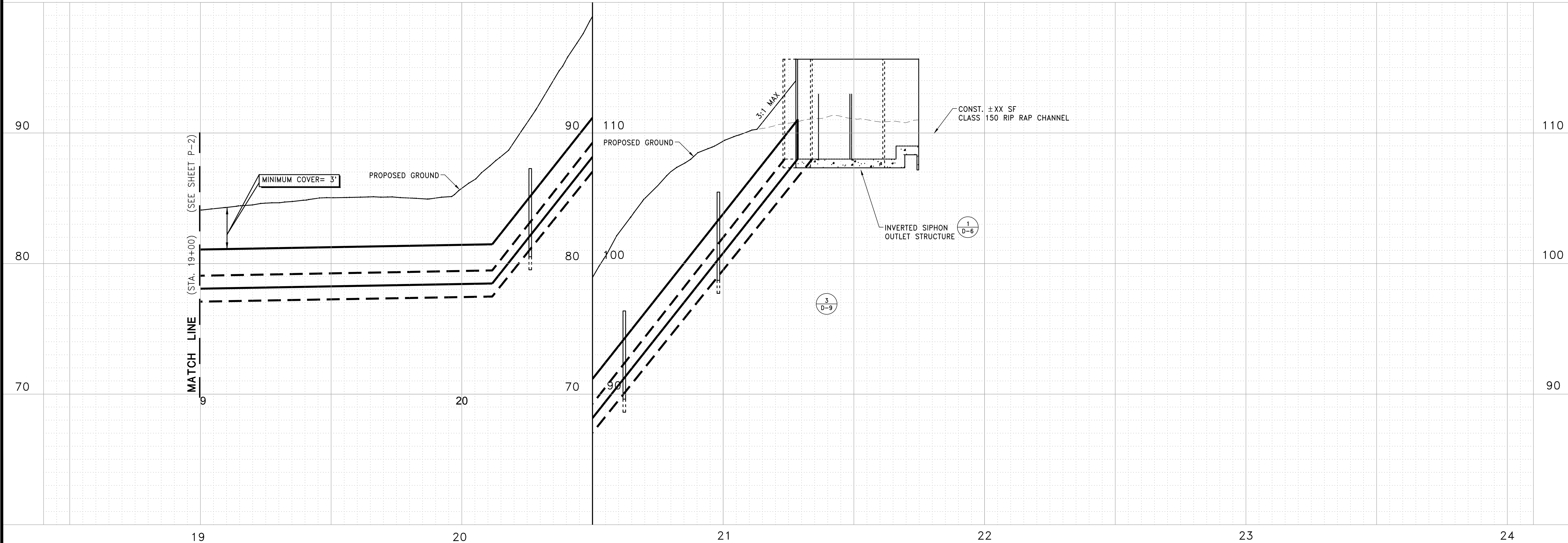

PRELIMINARY - DEVELOPMENT AGREEMENT SUBMITTAL

NO.	DESCRIPTION	DATE

DATE: APRIL 2019  
 SCALE: H:1"=20' V:1"=5'  
 DRAWN BY: DAD  
 DESIGNED BY: DAD  
 CHECKED BY: MAC



WOOD ROGERS  
 BUILDING RELATIONSHIPS ONE PROJECT AT A TIME  
 1981 Corporate Blvd  
 Reno, NV 89502  
 Tel: 775.825.4068  
 Fax: 775.823.4066



IMPROVEMENT PLANS FOR  
**ORR DITCH REALIGNMENT  
 INVERTED SIPHON**  
 PLAN AND PROFILE

PROJECT NO.  
8052.001  
 DRAWING  
**P-3**

J:\Users\8052.Washoe County School District\Widreack High School\ - Widreack HS Orr Ditch Realignment\Civil\Draw\010\_Plan\03\_WCHS\_BPI.dwg 3/27/2019 6:37 PM Doug Dai Pofo



**PK Electrical, Inc.**  
*Engineering · Design · Consulting*

March 25, 2019

Washoe County School District  
14101 Old Virginia Rd  
Reno, NV 89521

Attn: Adam T. Searcy, PE  
Chief Facilities Management Officer

RE: WCSD Wildcreek Area High School  
Stadium Sports Lighting

Dear Adam,

The stadium sports lighting for the new Wildcreek Area High School is currently under design. Preliminary lighting calculations are not yet available as they will be developed as we proceed into the Construction Document design phase.

The basis of design for the stadium lighting is the Musco Lighting Total Light Control—TLC for LED™ system. Overall system design shall include four (4) 70' poles with full cutoff dark sky compliant LED heads. The system's patented optics and glare control technology will help preserve the natural darkness around the stadium and will virtually eliminate light spill and glare onto the surrounding properties. Anticipated horizontal lighting levels on the field will be an average of 50 foot candles (FC) to comply with the Illuminating Engineering Society (IES) recommendations for outdoor high school level sporting events (football, track, etc.). At a 150' spill perimeter around the field, we anticipate an average of 0.00 FC horizontal illuminance and an average of 0.01 FC vertical illuminance. Glare at the spill perimeter is anticipated to be less than 500 candela, which is equivalent to a 100W incandescent light bulb.

Musco's TLC for LED™ system achieves a level of precision never before possible. It solves the ever enduring issue of how to put more light on your field, spill less around it, and reduce energy consumption and operating costs. The fixture heads are controlled light sources, not floodlights. The patented, customizable optics of the TLC for LED™ system can control the intense, "rifle shot" of LED light like no other lighting solution. The system will put a higher percentage of light precisely where you want it—on the field.

All this can be achieved while still preserving the night sky and being a good neighbor. The system is able to carve out the area to be lighted with pinpoint precision, dramatically cutting off any impact on the surrounding area. No more worrying about glare or spill impacting the area around your field. The system is capable of creating a brilliantly focused field for players and spectators, and a welcomed

681 Sierra Rose Drive, Suite B | Reno, Nevada 89511 | 775.826.9010  
5105 DTC Parkway, Suite 420 | Greenwood Village, Colorado 80111 | 720.481.3290

[www.pkelectrical.com](http://www.pkelectrical.com)

**Exhibit 13**

curtain of darkness for your neighbors—with less energy consumption and lower operating costs. See that attached LED Glare Comparison study by Musco.

PK Electrical has specified this product at the new TMCC Athletic Field in Reno, NV. The lighting calculations provided with the submittal exceeded expectations for light spill and glare. The system was also installed at Pershing County High School in Lovelock, NV with great success. Based on previous experience with this manufacturer and this specific product, it is our professional opinion that this design will provide the best quality of light on the field, while eliminating impact to the surrounding environment and neighborhoods.

Respectfully Submitted,

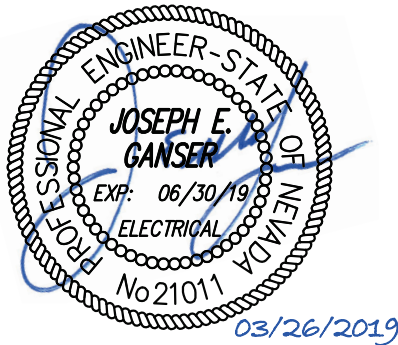

Joseph Ganser, PE  
Engineering Operations Manager  
PK Electrical, Inc.

CC:

Brian Martinezmoles, PE – Wood Rodgers, Inc.  
Mark Casey – Wood Rodgers, Inc

Attachments:

LED Glare Comparison – Musco Lighting



Musco: what can be



2014 Musco Light-Structure Green™ System with LED light source  
LakePoint Sporting Community · Emerson, Georgia, USA

What often is



2014 Other manufacturer's fixture with LED light source

For more than 35 years the Musco Team has focused on researching control of light energy to deliver affordable systems that minimize glare and spill . . . reduce energy . . . provide optimal environment for athletes, spectators, and HD broadcasts . . . and assure long term trouble-free operation.

# Wildcreek HS Football

Sparks, NV

## EQUIPMENT LAYOUT

### INCLUDES:

- Bleachers / Egress Path
- Stadium

**Electrical System Requirements:** Refer to Amperage Draw Chart and/or the "Musco Control System Summary" for electrical sizing.

**Installation Requirements:** Results assume  $\pm 3\%$  nominal voltage at line side of the driver and structures located within 3 feet (1m) of design locations.

## EQUIPMENT LIST FOR AREAS SHOWN

Pole		Luminaires			QTY/ POLE	
QTY	LOCATION	CLASS	GRADE ELEVATION	BOUNTING HEIGHT		LUMINAIRE TYPE
4	F1-F4	LSS80B	-	15.5' 70' 80'	TLC-BT-575 TLC-LED-400 TLC-LED-1500	2 1 9
TOTALS					48	

## SINGLE LUMINAIRE AMPERAGE DRAW CHART

Ballast Specifications (80 min power factor)	Line Amperage Per Luminaire (max draw)						
	208	220	240	277	347	380	480
Single Phase Voltage	208	220	240	277	347	380	480
TLC-LED-1500	9.0	8.5	7.8	6.7	5.4	4.9	3.9
TLC-BT-575	3.4	3.2	2.9	2.5	2.0	1.8	1.5
TLC-LED-400-A	2.3	2.2	2.0	1.7	1.4	1.3	1.0

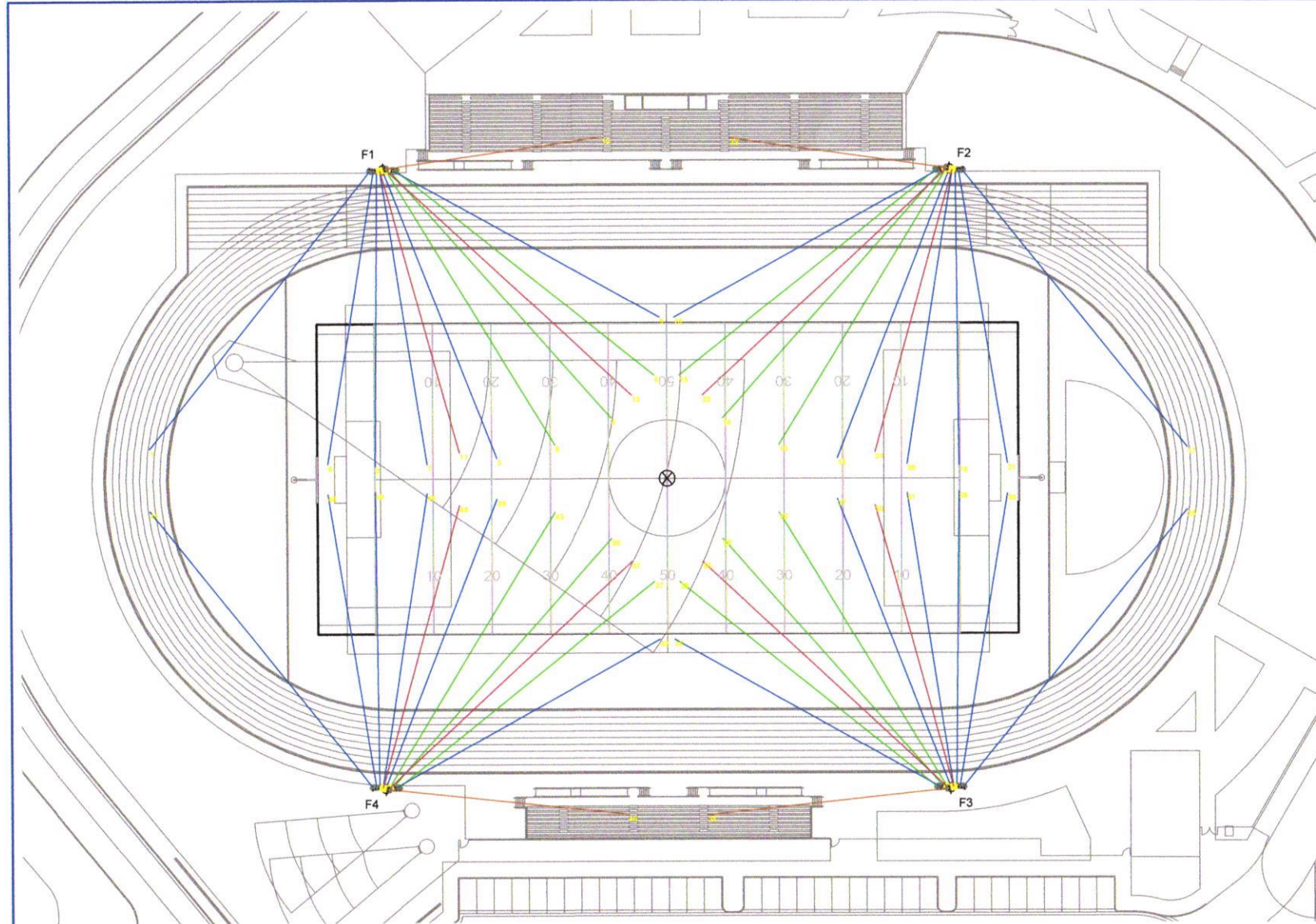

SCALE IN FEET 1 : 50



ENGINEERED DESIGN By: dalexander • File #197640A • 28-Mar-19

Pole location(s) Ⓧ dimensions are relative to 0,0 reference point(s) ⊗



**We Make It Happen.**

Not to be reproduced in whole or part without the written consent of Musco Sports Lighting, LLC. ©1981, 2019 Musco Sports Lighting, LLC.

EQUIPMENT LAYOUT

## Wildcreek HS Football

Sparks, NV

### GLARE IMPACT

#### Summary

Map indicates the maximum candela an observer would see when facing the brightest light source from any direction.

A well-designed lighting system controls light to provide maximum useful on-field illumination with minimal destructive off-site glare.

### GLARE

#### Candela Levels

**High Glare: 150,000 or more candela**  
Should only occur on or very near the lit area where the light source is in direct view. Care must be taken to minimize high glare zones.

**Significant Glare: 25,000 to 75,000 candela**  
Equivalent to high beam headlights of a car.

**Minimal to No Glare: 500 or less candela**  
Equivalent to 100W incandescent light bulb.

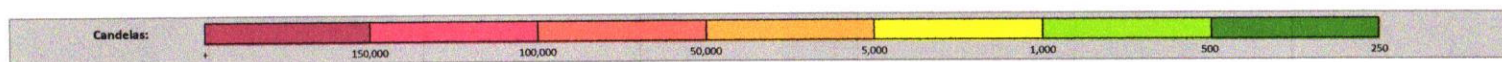
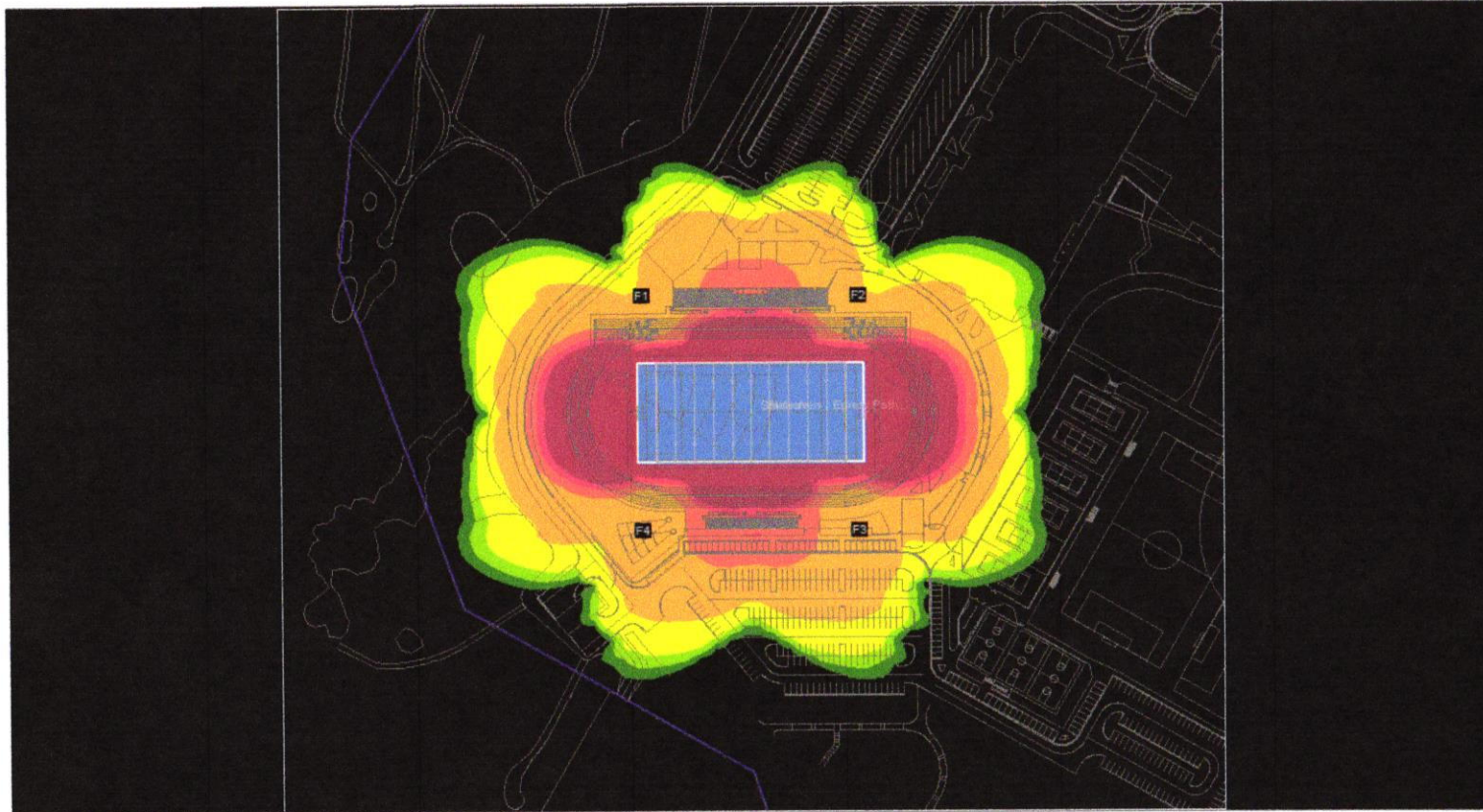

**We Make It Happen.**

Not to be reproduced in whole or part without the written consent of Musco Sports Lighting, LLC. ©1961, 2019 Musco Sports Lighting, LLC.

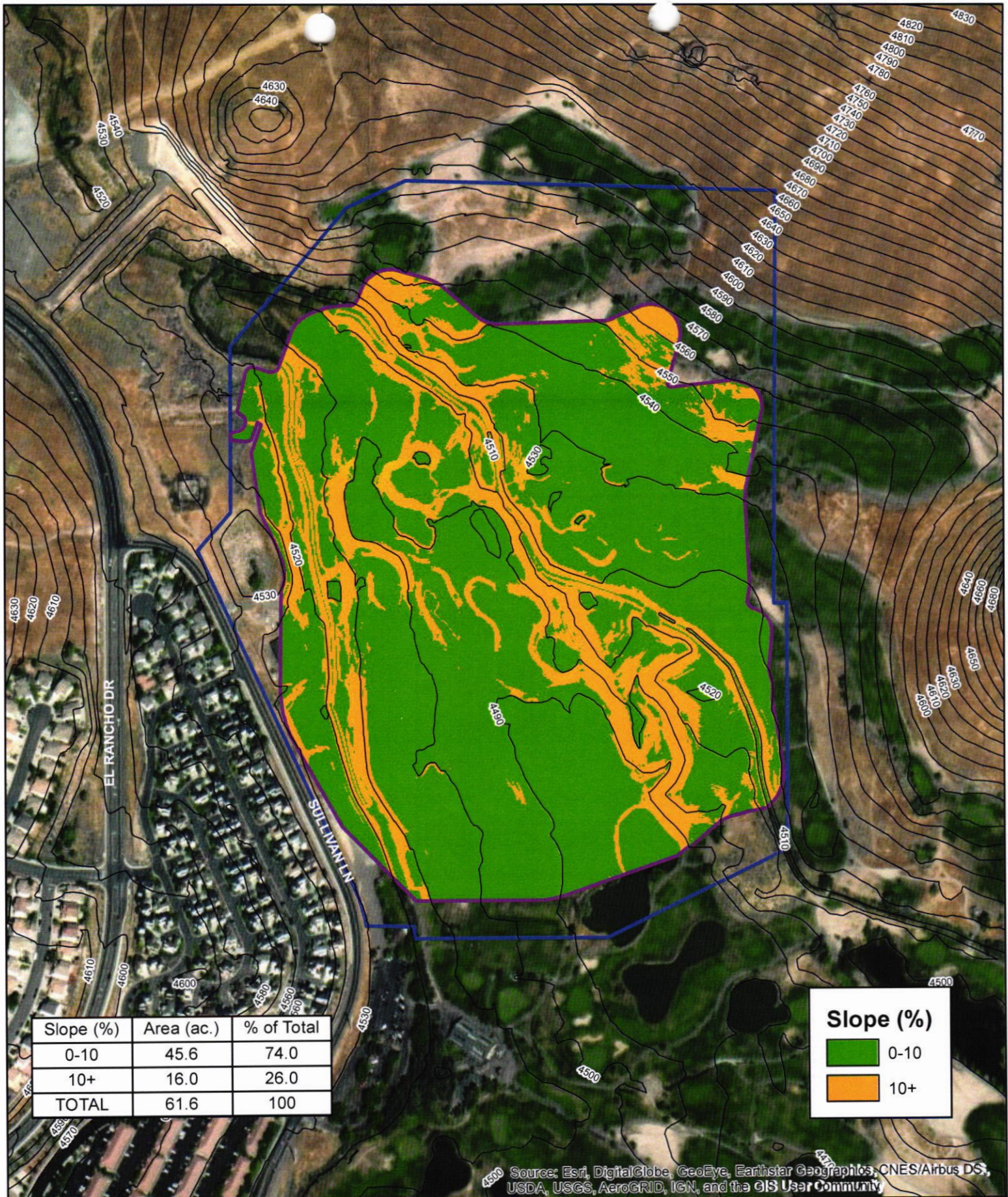

Slope (%)	Area (ac.)	% of Total
0-10	45.6	74.0
10+	16.0	26.0
<b>TOTAL</b>	<b>61.6</b>	<b>100</b>



Source: Esri, DigitalGlobe, GeoEye, Earthstar Geographics, CNES/Airbus DS, USDA, USGS, AeroGRID, IGN, and the GIS User Community

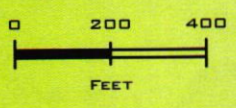

**Initial Slope Analysis**  
 High School at Wildcreek  
 Sparks, NV  
 January, 2019

## Exhibit 14

**WOOD RODGERS**  
 BUILDING RELATIONSHIPS ONE PROJECT AT A TIME  
 1361 Corporate Boulevard  
 Reno, NV 89502  
 Tel: 775.823.4068  
 Fax: 775.823.4066

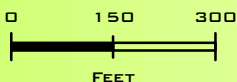
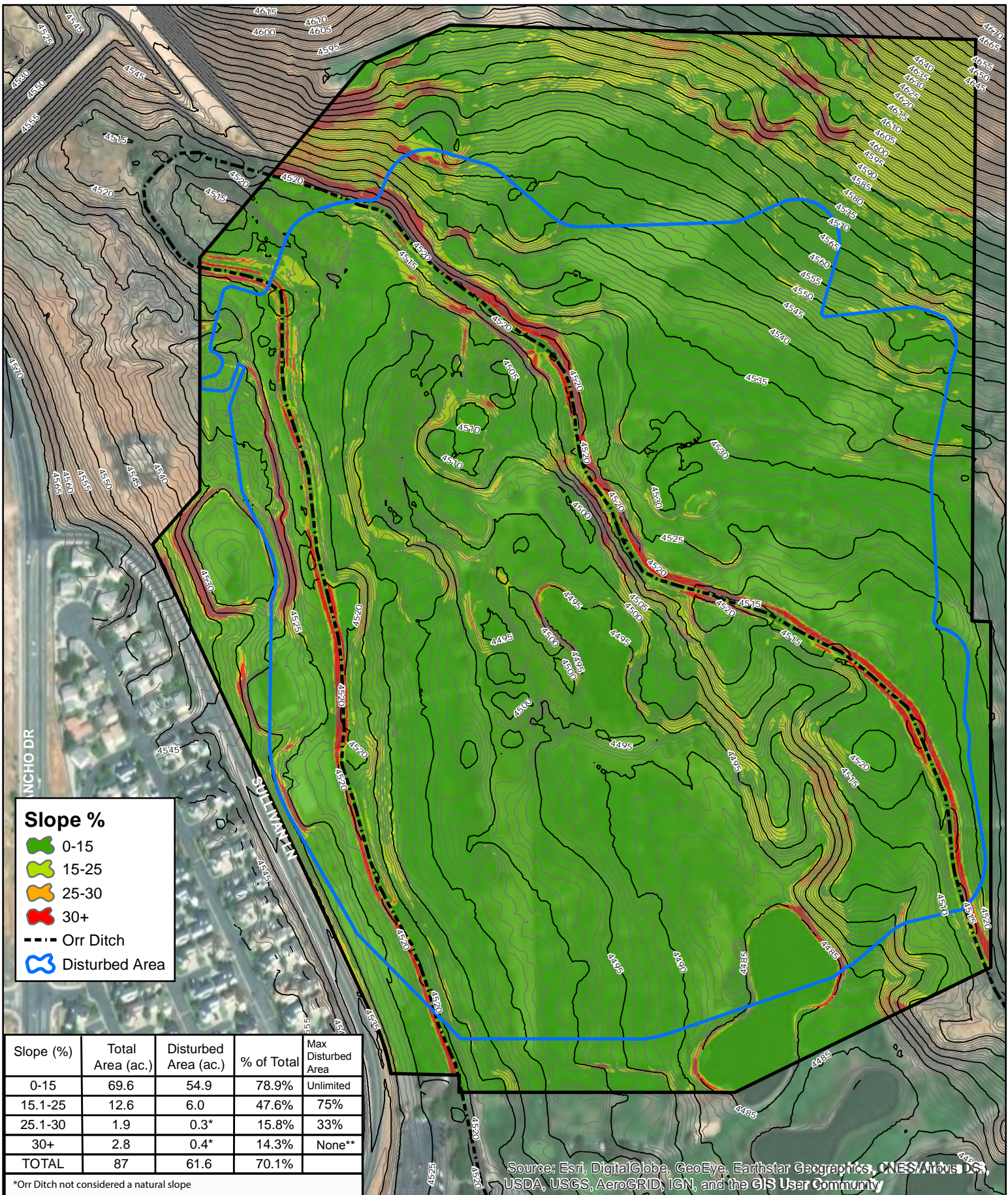

**Project Parcel Slope Analysis**  
 High School at Wildcreek  
 Sparks, NV  
 March, 2019

**Exhibit 15**

**WOOD RODGERS**  
 BUILDING RELATIONSHIPS ONE PROJECT AT A TIME  
 1361 Corporate Boulevard Tel: 775.823.4068  
 Reno, NV 89502 Fax: 775.823.4066



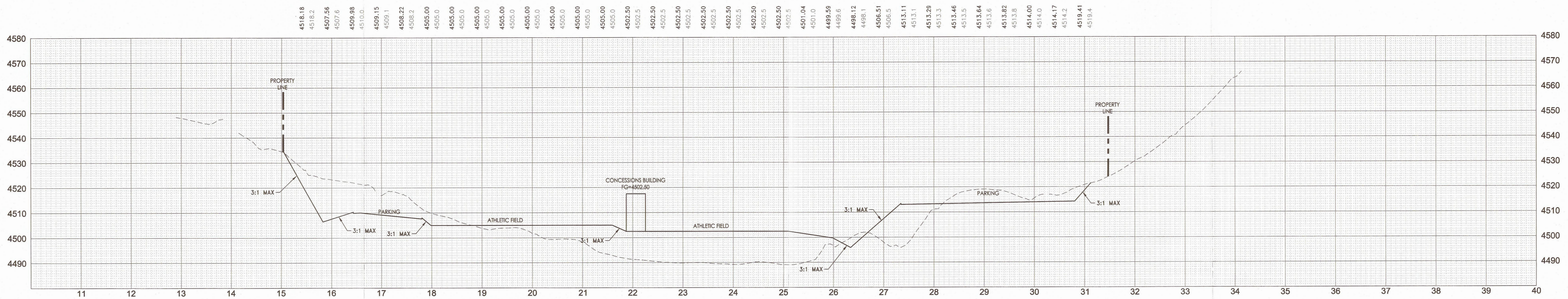

SECTION A

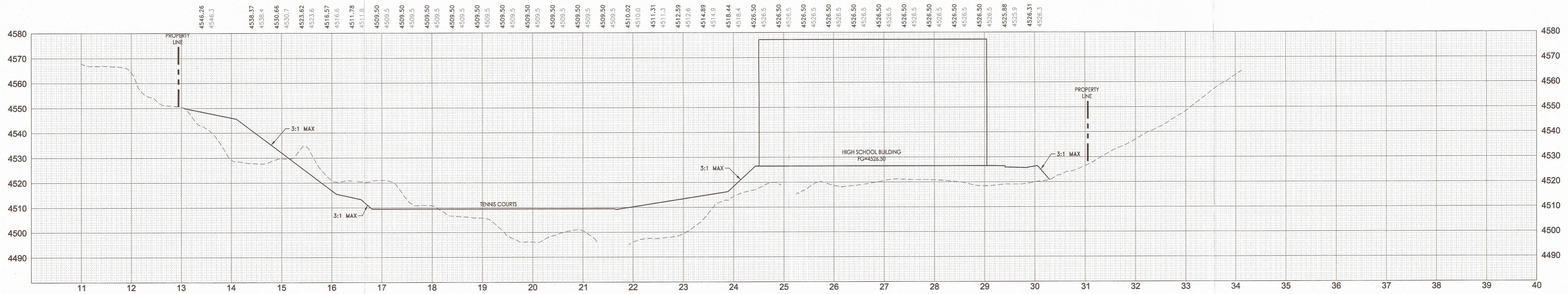

SECTION B

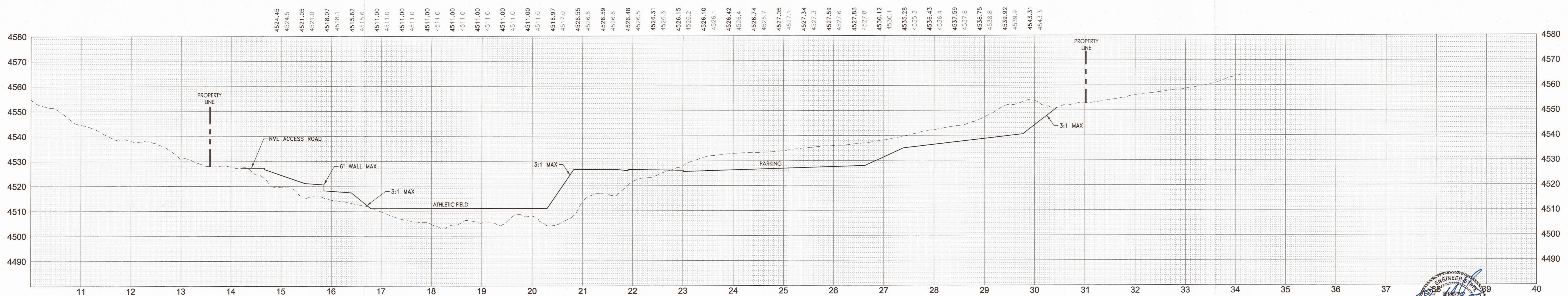

SECTION C

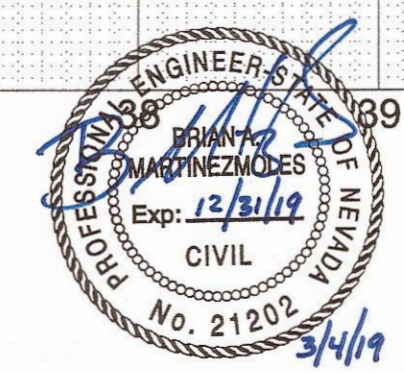

Professional Seal    Date    Revision

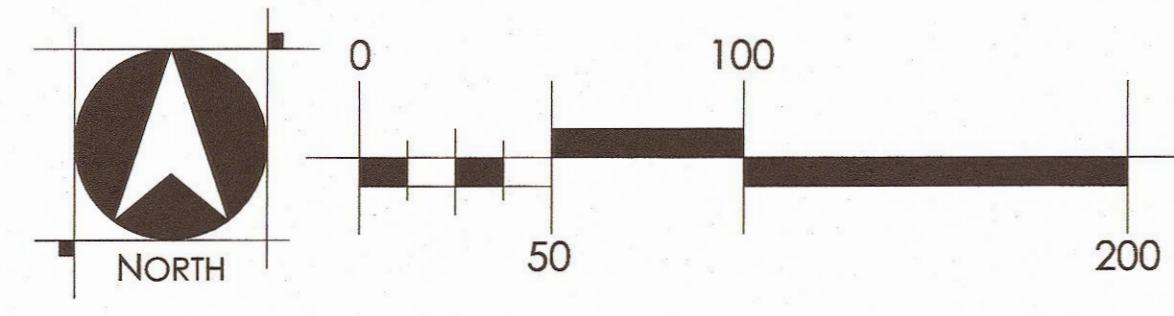

**Development Agreement**  
**Site Submittal Package**  
**PRELIMINARY**  
**Not For Construction**

© Copyright H + K Architects

**WOOD ROGERS**  
 BUILDING RELATIONSHIPS ONE PROJECT AT A TIME  
 1351 Corporate Boulevard    Tel 775.823.4088  
 Reno, NV 89502    Fax 775.823.4066

Consultant:  
**CUNNINGHAM ARCHITECTS**  
 P 812.379.3400  
 F 812.379.4400  
 www.cunningham.com

Design Architect:  
**H+K ARCHITECTS**  
 5485 Reno Corporate Drive, Suite 100  
 Reno, Nevada 89511-2262  
 P 775+332+6640  
 F 775+332+6642  
 hkarchitects.com

Architect of Record:  
**Wildcreek Area High School**  
**Washoe County School District**  
 Sullivan Lane  
 Sparks, Nevada 89431

SITE SECTION VIEW  
 SHEET 2 OF 3  
 02/20/2019  
 H+K Project No: 1733



02/20/2019 4:22:49 PM B:\361\1733 WCSO Wildcreek HS\WCSO - Wildcreek HS - A3.rvt

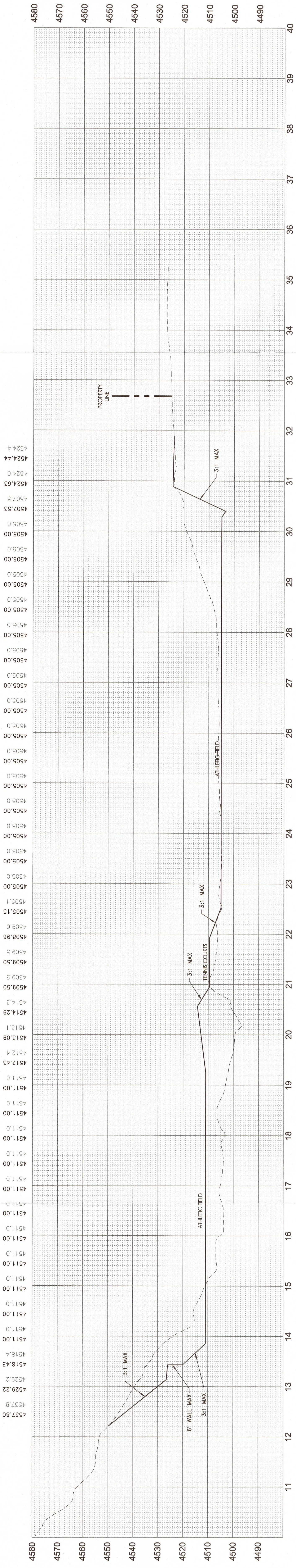

SECTION D

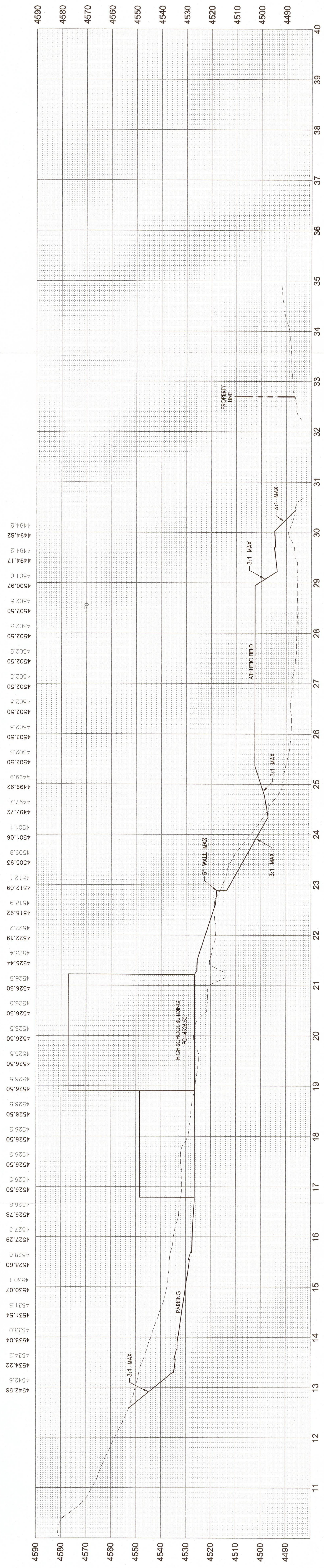

SECTION E

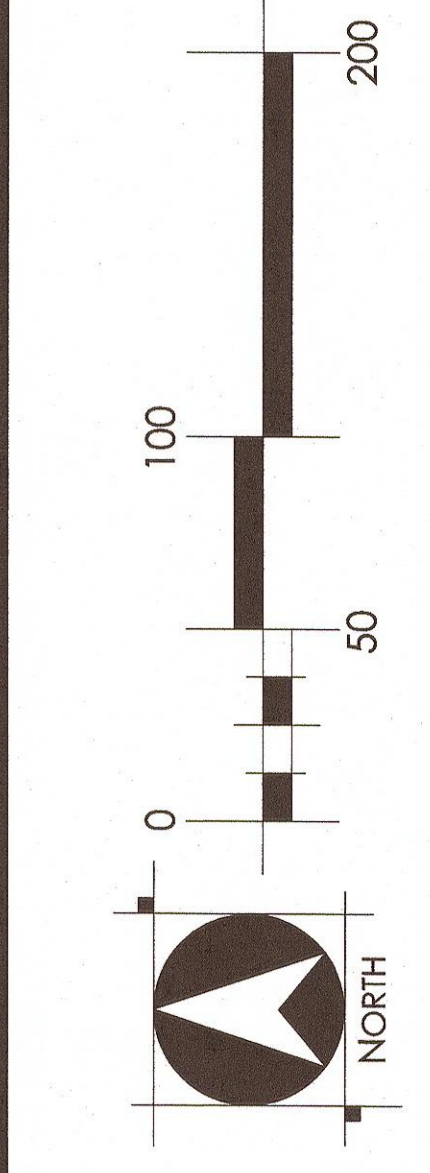

Development Agreement  
Site Submittal Package  
**PRELIMINARY**  
Not For Construction

Revision	Date

**WOOD ROGERS**  
BUILDING RELATIONSHIPS ONE PROJECT AT A TIME  
1000 S. Virginia Street  
Reno, NV 89502    Phone: 775.823.4088    Fax: 775.823.4088

**H+K ARCHITECTS**  
5485 Reno Corporate Drive, Suite 100  
Reno, Nevada 89511-2262  
P 775-332-6640  
F 775-332-6642  
hkarchitects.com

Architect of Record  
**H+K ARCHITECTS**  
5485 Reno Corporate Drive, Suite 100  
Reno, Nevada 89511-2262  
P 775-332-6640  
F 775-332-6642  
hkarchitects.com

**Wildcreek Area High School  
Washoe County School District**  
Sullivan Lane  
Sparks, Nevada 89431

SITE SECTION VIEW  
SHEET 3 OF 3  
02/20/2019  
H+K Project No: 1733



# Exhibit 17

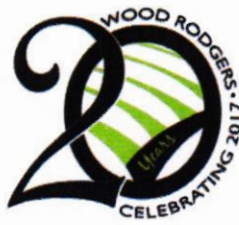

November 13, 2017

Washoe County School District  
Mr. Adam Searcy, P.E.  
Deputy Facilities Officer  
14101 Old Virginia Road  
Reno, NV 89521

RECEIVED-CITY OF SPARKS

FEB 22 2019

COMMUNITY SERVICES  
ADMINISTRATION

*Job Number: 8052.015*

**Re: High School Campus at Wildcreek Due Diligence Services  
Task 5.4 - Preliminary FAA Airspace Review**

Dear Adam:

The following letter outlines the conclusions derived from the Preliminary Airspace Review conducted as part of the potential High School at Wildcreek due diligence studies. The existing Wildcreek property consists of 330.7± acres within the City of Sparks approximately 3 miles north of the Reno-Tahoe International Airport. North McCarran Boulevard borders the site to the south, Sullivan Lane borders the site on the west, with single family residential bordering the site on the east. The potential development of the site includes a high school campus with associated educational building, athletic facilities, parking and necessary landscaping and drainage facilities. As part of this due diligence review, a preliminary FAA Airspace Review, Aircraft Noise analysis and Site Lighting analyses were completed.

## **FAA Airspace Review**

The proposed campus will be located within (3) three nautical miles of the Reno-Tahoe International Airport (RNO) and under the approach/departure paths for Runways 16L-34R and 16R-34L. Due to the proximity of the site to the RNO, any potential development must comply with Title 14 Code of Federal Regulations (Aeronautics and Space) Part 77 (Safe, Efficient Use, and Preservation of the Navigable Airspace) requirements, otherwise known as Part 77.

Part 77 establishes requirements to notify the Federal Aviation Administration (FAA) of certain proposed constructions and alterations, the standards to determine obstructions in relation to air navigation and navigational and communications facilities, and the process to study obstructions and their effect on the safe and efficient use of navigable airspace, facilities, and equipment. The FAA notification process allows the FAA, which controls airspace, to evaluate the effect of a proposed construction or alteration on safety in air commerce, on the efficient use and preservation of the navigable airspace, and on airport traffic capacity at public use airports. In addition, this process determines whether the effect is a hazard to air navigation, whether there are appropriate measures to be applied for the continued safety of air navigation, whether the aviation community must be notified about objects affecting navigable airspace, and whether navigational charts require updating.

Part 77 consists of (5) five imaginary surfaces (horizontal, conical, primary, approach, and transitional) that protect the airspace around airports. An object, such as any natural growth (foliage), terrain, or structure (permanent or temporary) which penetrates the elevation of any of the referenced surfaces requires formal notification to the FAA. In addition to the Part 77 surfaces, the FAA notification requirement for the proposed campus is triggered if an object will exceed 200 feet above ground level at the site or if an object will exceed a surface extending outward and upward at a slope of 100:1 for a horizontal distance of 20,000 feet from the nearest point of the nearest runway. The FAA notification requirement allows the FAA to further study any penetration and determine whether or not it creates an obstruction which may pose a hazard to air navigation. The FAA notification requirement is met by the timely filing of an FAA Form 7460-1, Notice of Proposed Construction or Alteration.

Based on proximity to the airport, the potential development lies underneath the Part 77 approach surface of RNO. The approach surface is centered longitudinally on the runway centerline and extends outward and upward from the runway end at a 50:1 slope for 10,000 feet with an additional 40:1 slope for 40,000 feet. The 2011 Airport Layout Plan (ALP) for RNO was utilized to establish the vertical and horizontal location of the runway ends from where the surface is referenced. The Part 77 approach surface contours shown on Figure 1 represent the developable elevation at any point within the proposed site before penetration of the Part 77 approach surface. Any structure that exceeds the elevation of the approach surface should be considered a penetration and will require evaluation by the FAA to determine whether or not the penetration is also an obstruction.

In addition to verifying the Part 77 approach surface, the Reno-Tahoe Airport Authority (RTAA) requires the One-Engine Inoperative (OEI) departure surface be maintained without obstruction. The OEI surface is centered longitudinally on the runway centerline and extends outward and upward from the runway end at a 62.5:1 slope for 50,000 feet. Per the 2011 RTIA ALP, Runways 34L and 34R do not include a clearway; therefore, the OEI surface was determined from the runway end. The OEI surface contours shown on Figure 2 represent the developable elevation at any point within the proposed site before penetration of the OEI surface. Although the OEI surface is the control surface setting the projected maximum structure elevation within the proposed development, the 100:1 surface is the elevation triggering FAA notification requirement.

Based on our review of RTAA and FAA airspace requirements the site can be developed without creating an airspace surface obstruction. Building height(s) and site/athletic lighting should be monitored during final design to ensure all proposed structures maximum elevation are below the OEI surface and any planned structures exceeding the 100:1 surface should be included in an FAA notification prior to construction. The maximum developable building elevations are shown in Figure 2 and vary throughout the site. Final allowable building heights will vary depending on location on the site and proposed finish grade elevations; however, a structure height of 150' or less can be constructed (from existing ground elevation) without creating an airspace obstruction regardless of location on the site. It should be noted that the maximum developable elevation is determined from the OEI surface regardless of site grading.

### **Reno-Tahoe International Airport Noise Exposure**

RNO noise contours were reviewed in relation to the project site to determine if noise mitigation would be required as part of the potential development. Based on the FAA-approved noise contours for RNO, the

project site resides outside of the 65 decibel (dBA) Day-Night Sound Level (DNL) noise contour. The DNL represents noise exposure events over a 24-hour period, with noise between the hours of 10:00 p.m. and 7:00 a.m. receiving a “penalty” to reflect increased sensitivity during those hours. Each event between 10:00 p.m. and 7:00 a.m. is measured as if 10 similar daytime events occurred. The FAA recommends noise mitigation measures to noise-sensitive facilities, such as residences or schools, within the 65 dBA DNL noise contour. Recommended mitigation measures include construction methods and materials to attenuate aircraft noise exposure to a maximum interior noise level of 45 dBA DNL for all noise-sensitive facilities such as classrooms, offices, and libraries.

Mitigation for any facility outside the 65-decibel contour is optional and while not required, noise mitigation should be considered during final design of the facility due to potential of limited loud single event occurrences, during normal aircraft operations over project area.

### Field Lighting Considerations

The High School at Wildcreek is currently proposed with several athletic fields, each of which has the potential of being lit for nighttime activities. Due to the proximity of the project to the RNO flight path, care should be taken to ensure any proposed lighting facilities are constructed with light shields and aimed appropriately to not impact pilots, aircraft operations, or aircraft control tower operations. Additionally, light fixtures should be adjustable, which would allow the lights to be re-aimed as necessary to account for pilot feedback after final installation. Washoe County School District (WCSD) has previously successfully coordinated with the RTAA and the FAA for other athletic facilities within the region. During the design phase of this facility it is recommended the WCSD work with the RTAA and the FAA to coordinate the final light fixture types as well as light aiming to limit any impact on aviation activities.

In summary, the project site has been preliminarily reviewed for probable limitations to development because of air navigation, aircraft noise impacts and site lighting impacts. We have found that these considerations do not preclude development of the project site into a potential high school campus. Final site and building design will have to consider these potential impacts to ensure the final campus solution works in conjunction with the surrounding aviation activities.

Sincerely,  
Wood Rodgers, Inc.



Stephen Hughey, P.E.  
Project Engineer

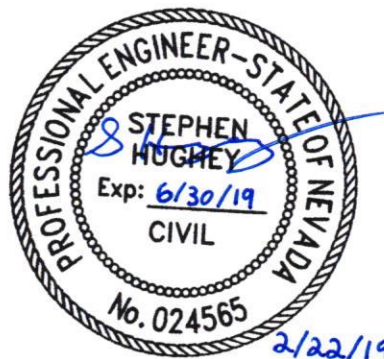

Attachments: *Figure 1 – FAA Part 77 Approach Slope – Max Developable Elevations*  
*Figure 2 – OEI Departure Slope – Max Developable Elevations*

# PART 77 APPROACH SLOPE - MAX DEVELOPABLE ELEVATIONS HIGH SCHOOL AT WILDCREEK

SPARKS, NEVADA  
NOVEMBER, 2017



FIGURE 1

# ONE-ENGINE INOPERATIVE - MAX DEVELOPABLE ELEVATIONS HIGH SCHOOL AT WILDCREEK

SPARKS, NEVADA  
NOVEMBER, 2017



FIGURE 2

200.0 ft. Horiz. Scale  
40.0 ft. Vert. Scale



PROPOSED 120KV LINE  
LENGTH = 3963 FT

EXISTING LINE TO BE REMOVED  
LENGTH = 3028 FT

BEGIN RELOCATION

END RELOCATION

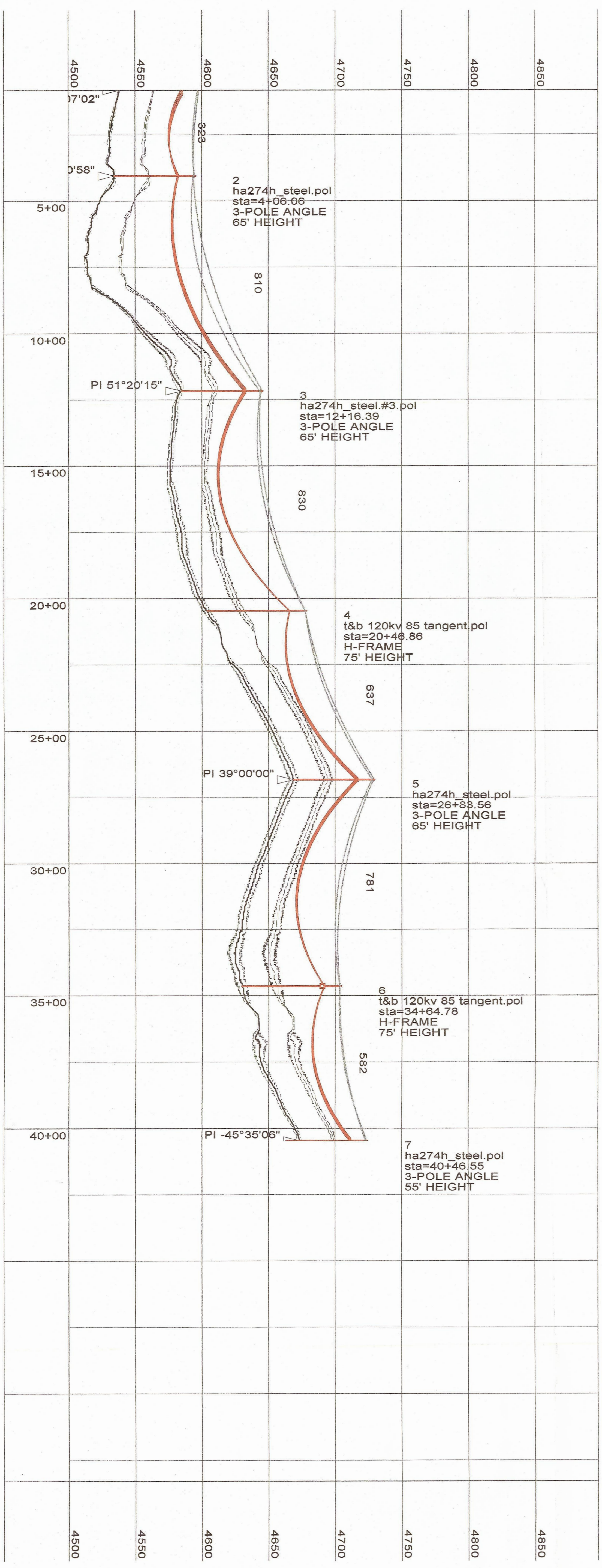

# Exhibit 18

WILDCREEK  
120KV LINE RELOCATION  
PROPOSED - NOT FOR CONSTRUCTION



NO	DATE	DESCRIPTION	DWN	ENGR	APPR	PROJECT #
1	5/21/18	PLAN AND PROFILE	AFM	JAL		
2						
3						
4						
5						
6						
7						

DESIGN SUMMARY	
SHIELD WIRE	-
CONDUCTOR	-
DESIGN L-G CLEAR	-
DESIGN LOADING	-
IN-SERVICE	-

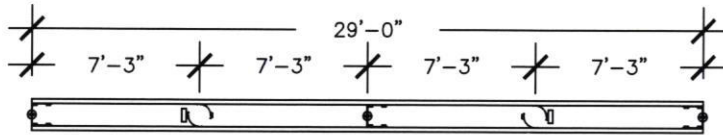

TOP VIEW

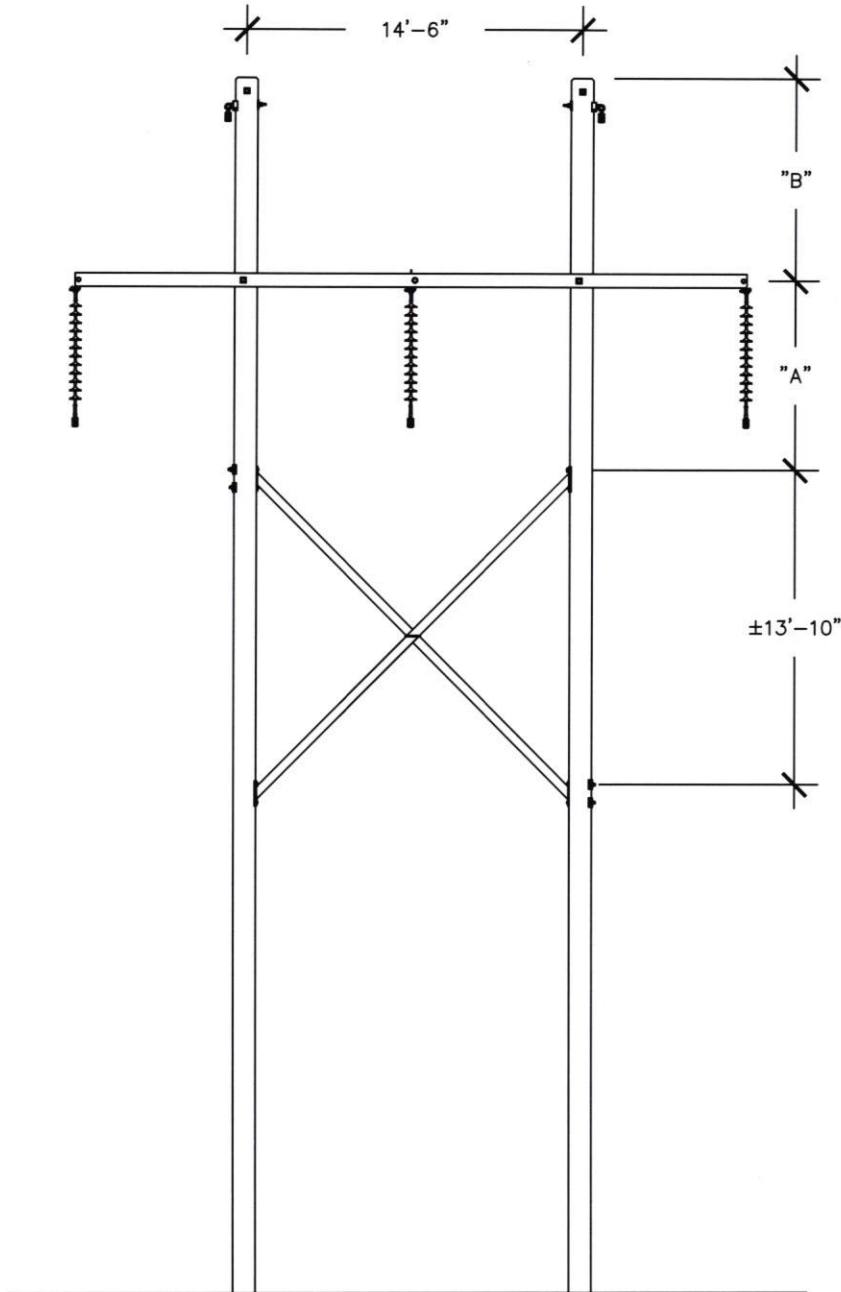

ELEVATION

PERMITTING ONLY. NOT VALID FOR CONSTRUCTION.



Volume 6: 120kV STRUCTURE STANDARDS

H-FRAME TANGENT W/DOUBLE TUBE ARM  
& STATIC WIRE 14'-6" POLE SPACING  
POLYMER

DT274H

DRAWN:	ENG:	APPR:	DATE:
AFM	JAL	--	02/2019

REVISION: 01  
PAGE 1 OF 1

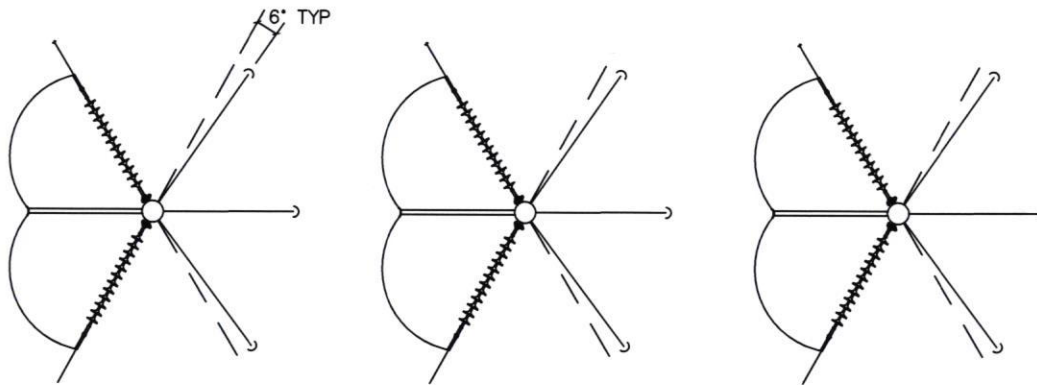

TOP VIEW

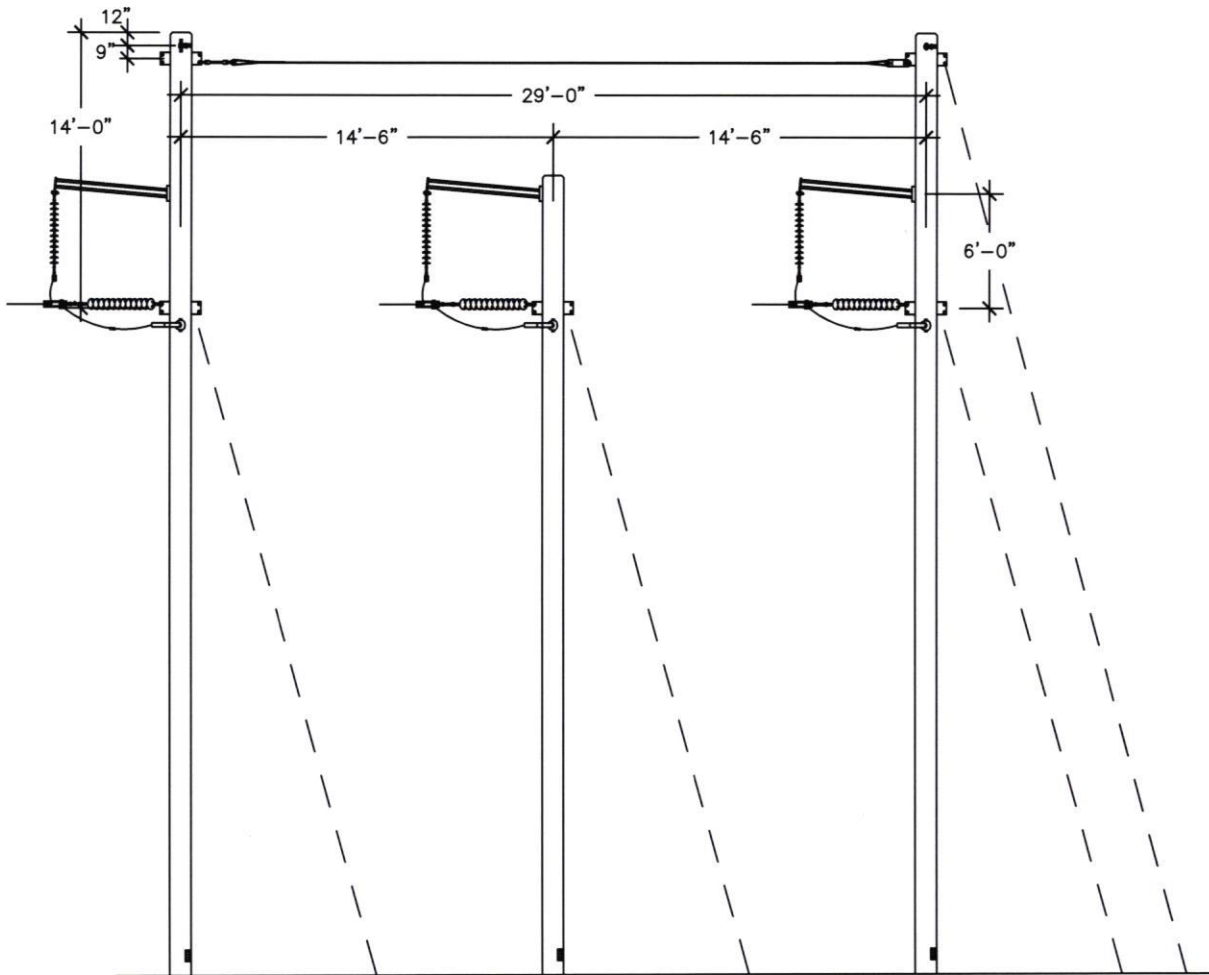

ELEVATION

PERMITTING ONLY. NOT VALID FOR CONSTRUCTION.



**VOLUME 6: 120KV STRUCTURE STANDARDS**

**3-POLE HEAVY ANGLE DEAD END  
 $\frac{3}{8}$ " STEEL SHIELD WIRE  
 STEEL POLES**

**HA274H**

DRAWN:	ENG:	APPR:	DATE:
AFM	JAL	--	02/2018

REVISION: 00  
 PAGE 1 OF 1



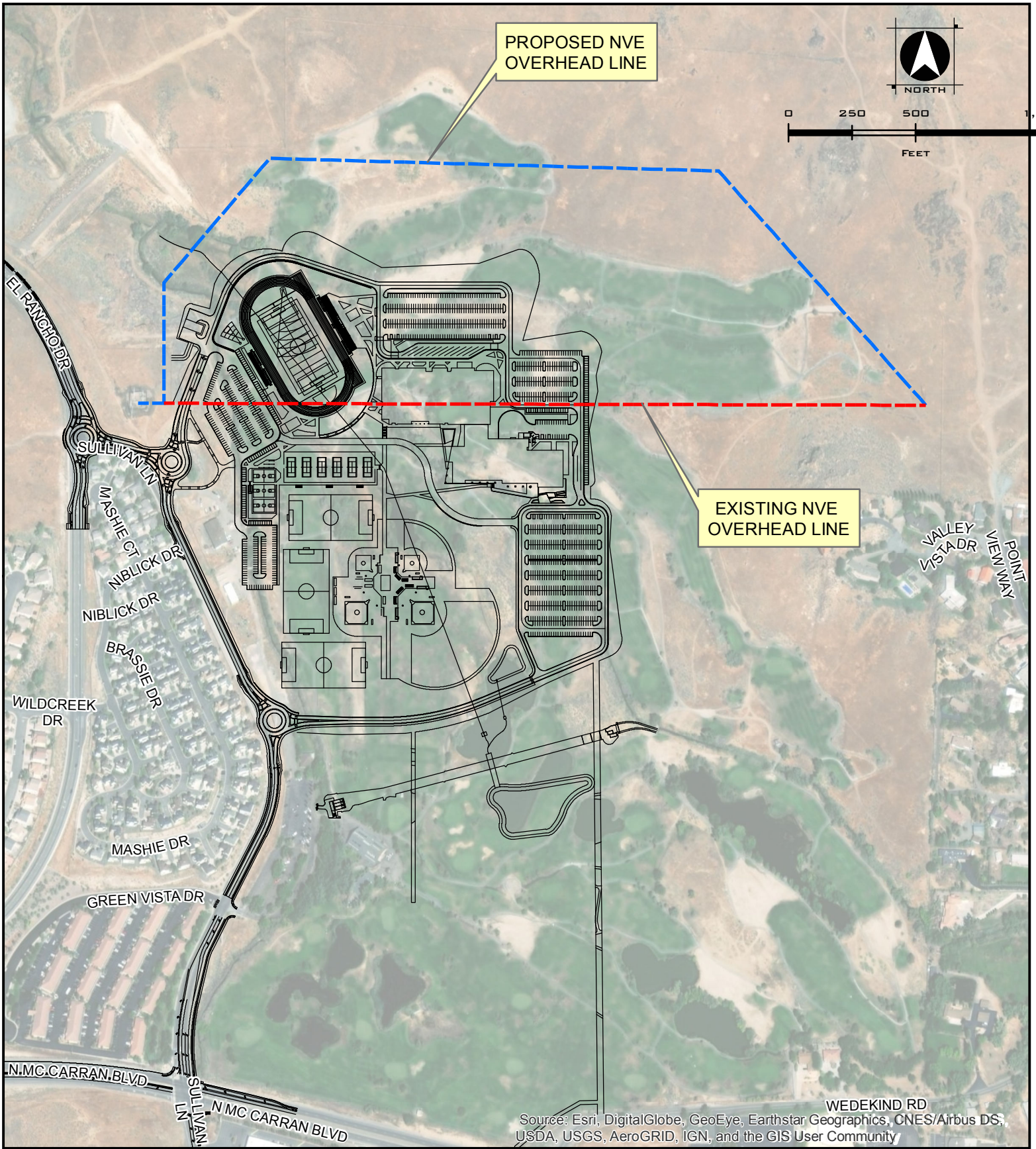

**Washoe County School District**  
Every Child, By Name And Face, To Graduation™

**NVE OVERHEAD LINE REALIGNMENT  
HIGH SCHOOL AT WILDCREEK  
SPARKS, NV  
APRIL, 2019**



**WOOD RODGERS**  
BUILDING RELATIONSHIPS ONE PROJECT AT A TIME  
1361 Corporate Boulevard Tel: 775.823.4068  
Reno, NV 89502 Fax: 775.823.4066